

IPD3005C

DIGITAL KWH METER 5A , CT CONNECT 415V RS485 MODBUS COMMUNICATION DIN MTG. ENERGY MANAGEMENT > NMI/SUB-BILLING METERING > THREE PHASE MULTIFUNCTION METER

OVERVIEW

The IPD3005C series Digital Three-Phase Energy Meter is IPD's latest offer for the low voltage power/energy metering market featuring DIN rail mount, high accuracy, multifunction true RMS measurements and a large, easy to read LCD display. The IPD3005C series complies with IEC 62053-22 Class 0.5S kWh accuracy standards for 5A CT Input. The IPD3005C series comes standard with a metrological LED as well as a Solid State Pulse Output for energy pulsing. The IPD3005C series provides 2MB memory for Data Recording and 3 Digital Inputs for status monitoring, Tariff switching or pulse counting for collecting Water, Air, Gas, Electric and Steam information from 3rd party metering devices. The standard RS-485 port and Modbus protocol support allows the IPD3005C series to become a vital component of an intelligent, multifunction monitoring solution for any Power and Energy Management Systems.



DIMENSIONS AND INSTALLATION

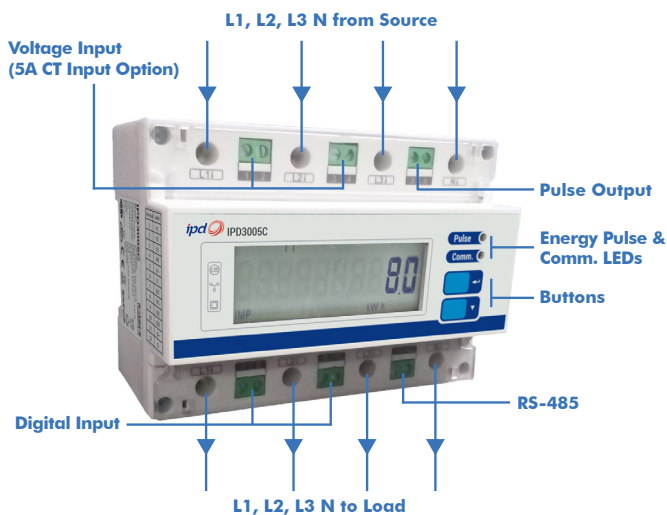

DIMENSIONS AND INSTALLATION

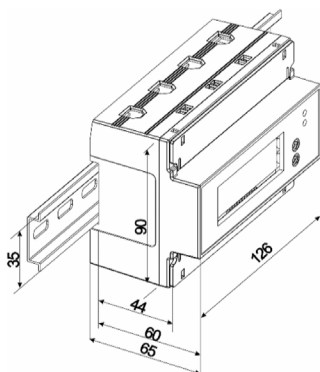

FEATURES

Ease of use

- Large, easy to read LCD
- Two LED indicators for energy pulsing and communication activities
- Password-protected setup via front panel
- Easy installation with DIN rail mounting, no tools required
- 3-phase power supply, no external control power required

Basic Measurements

- Multifunction True RMS measurements
 - Voltage, Current, kW, kvar, kVA, PF, Phase Angle and Frequency
 - Per phase and Total kWh and kvarh Imp/Exp/Tot/Net and kVAh
 - 4-Quadrant kvarh
 - Device Operating Time (Running Hour)
 - Voltage and Current THD, TOHD, TEHD, Individual Harmonics up to 31st and unbalance
 - Current K-Factor, Crest Factor, TDD, TDD Odd and TDD Even
 - I1, I2, I3, kW/kvar/kVA Total Demands and Max. Demands
- Max/Min Log
- 12 monthly recording of kWh/kvarh Imp/Exp/Tot/Net, kVAh, kvarh Q1-Q4 as well as kWh/kvarh Imp/Exp and kVAh per Tariff
- Two TOU schedules, each providing
 - 12 Seasons
 - 20 Daily Profiles, each with 12 Periods in 15-minute interval
 - 90 Holidays or Alternate Days
 - 4 Tariffs, each providing the following information
 - o kWh/kvarh Import/Export, kVAh
 - o kW/kvar/kVA Max. Demands
- 2MB Log Memory
- Data Recorder Log of 16 measurements @ 10-minute interval for 197 days
- 16 SOE events time-stamped to 1ms resolution
- Front Panel & Communication Programming Counters

Digital Inputs

- 3 channels for external status monitoring and pulse counting
- Self-excited, internally wetted at 24VDC

Pulse Outputs

- 1 Front Panel LED and 1 Solid State Pulse Output for energy pulsing application

Communications

- Optically isolated RS485 port, baud rate from 1200 to 19,200 bps
- Modbus RTU protocol

Real-time Clock

- Battery-backed real-time clock @ 6ppm
- Clock error \leq 0.5s/day

System Integration

- Easy integration into other Automation or SCADA systems via Modbus RTU protocol

TYPICAL APPLICATIONS

- DIN rail mount energy metering
- Industrial and commercial metering
- Substation, building and factory automation
- Sub-metering
- Power quality monitoring
- NMI Pattern Approval Metering

IPD3005C

SPECIFICATIONS

Part No.	IPD3005C
Inputs (L1, L2, L3, N)	
Voltage (Un)	240VLN
Range	0.7 to 1.1 Un
Burden	<10VA/phase
CT Input	
Current (In/Imax)	5A/6A
Range	(0.1%-120%) In
Starting Current	0.1% In
Burden	<0.5VA/phase
Frequency	45Hz-65Hz
Solid State Energy Pulse Output (Selectable - kWh/kvarh)	
Pulse Constant	1/10/100/1000/3200 imp/kWh (imp/kvarh)
Isolation	Optical
Max. Load Voltage	80V
Max. Forward Current	50mA
Pulse Width	60-150ms
Communications	
RS-485	Modbus RTU
Baudrate	1200/2400/4800/9600/19200 bps
Maximum Wire Size	1.5mm ² (16AWG)
Maximum Torque	0.45 N.m
Environmental Conditions	
Operating temp.	-25°C to +70°C
Storage temp.	-40°C to +85°C
Humidity	5% to 95% non-condensing
Atmospheric pressure	70 kPa to 106 kPa
Pollution Degree	2
Mechanical Characteristics	
Mounting	DIN Rail
Unit Dimensions	126x90x65mm
Shipping Dimensions	165x140x110mm
Shipping Weight	TBD
IP Rating	51 (Front), 30 (Body)

ACCURACY

Parameters	Accuracy	Resolution
Voltage	±0.5%	0.01V
Current	±0.5%	0.001A
kW, kvar, kVA	±1%	0.01kW/kvar/kVA
kWh, kVAh	IEC 62053-22 Class 0.5S for 5A CT Input	0.01kWh
kvarh	IEC 62053-23 Class 2	0.01kvarh
P.F.	±1%	0.001
Frequency	±0.02Hz	0.001Hz
Harmonics	IEC 61000-4-7 Class B	0.1%

IPD3005C

STANDARDS OF COMPLIANCE

Safety Requirements

CE LVD 2014 / 35 / EU	EN 61010-1: 2010 / EN 61010-2-030: 2010
Insulation	IEC 62052-11: 2003, NMI M6-1
AC Voltage	4kV @ 1 minute
Impulse voltage	10kV, 1.2/50µs (NMI M6-1)
Electrical safety in low voltage distribution systems up to 1000Vac and 1500Vdc	IEC 61557-12: 2008 (PMD)

**Electromagnetic Compatibility
CE EMC Directive 2014 / 30 / EU (EN 61326: 2013)**

Immunity Tests

Electrostatic discharge	EN 61000-4-2: 2009
Radiated fields	EN 61000-4-3: 2006+A1: 2008+A2: 2010
Fast transients	EN 61000-4-4: 2012
Surges	EN 61000-4-5: 2006
Conducted disturbances	EN 61000-4-6: 2009
Magnetic Fields	EN 61000-4-8: 2010
V Dips, Interruptions & Variations	EN 61000-4-11:2004
Oscillatory waves	EN 61000-4-12: 2006
Radio Disturbances	CISPR 22:2006, Level B

Emission Tests

Limits and methods of measurement of electromagnetic disturbance characteristics of industrial, scientific and medical (ISM) radio-frequency equipment	EN 55011: 2009 + A1: 2010 (CISPR 11)
Limits and methods of measurement of radio disturbance characteristics of information technology equipment	EN 55022: 2010+AC: 2011 (CISPR 22)
Limits for harmonic current emissions for equipment with rated current ≤16 A	EN 61000-3-2: 2014
Limitation of voltage fluctuations and flicker in low-voltage supply systems for equipment with rated current ≤16 A	EN 61000-3-3: 2013
Emission standard for industrial environments	EN 61000-6-4: 2007+A1: 2011
Testing and measurement techniques- Ring wave immunity test.	EN 61000-4-12: 2006

Mechanical Tests

Spring Hammer Test	IEC 62052-11: 2003
Vibration Test	IEC 62052-11: 2003
Shock Test	IEC 62052-11: 2003

Revenue Metering Approval

NMI M-6 of Australia	Approval Mark: NMI 14/2/102
----------------------	-----------------------------